

Coating Thickness Tester

With Bluetooth[®]

Model CG304

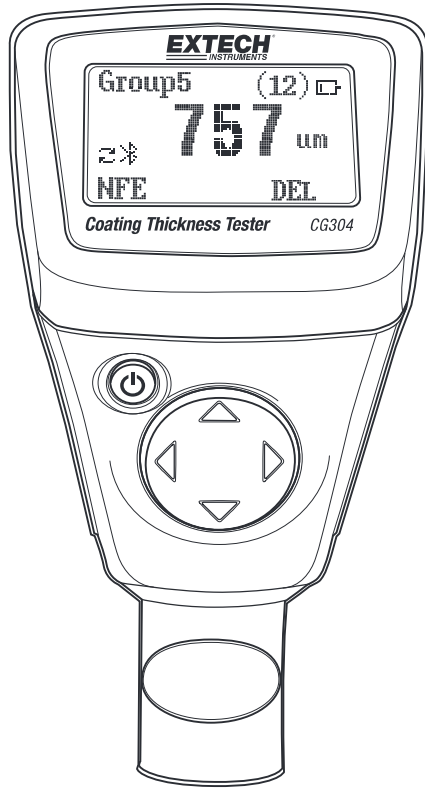

Introduction

Thank you for selecting the Extech CG304 Coating Thickness Tester. The CG304 is a portable meter designed for non-invasive coating thickness measurements with automatic recognition of the material under test.

The meter uses two measurement methods: magnetic induction (for ferrous metal substrates) and eddy current (for non-ferrous metal substrates).

The Bluetooth® feature wirelessly transmits measurement data to a Bluetooth receiving device for further analysis and for generating report documentation.

Proper use and care of this meter will provide many years of reliable service.

Features

- Measured Coatings: Non-magnetic coatings (e.g. paint, zinc) on steel; Insulated Coatings (e.g. paint, anodized coatings) on non-ferrous metals
- Intuitive menu-based programming
- Memory storage of up to 2500 readings in 50 groups (50 readings per group)
- Delete single readings or reading groups easily
- Bluetooth® data transfer to PC, phone, tablet or other device
- Auto Power OFF with disable feature
- User Zero Calibration ability

Applications

- Corrosion protection
- Paint Shops and Electroplaters
- Chemical, Automobile, Shipbuilding, and Aircraft industries
- Laboratory, Workshop, and Field use

Probe Description

The CG304 probe is spring mounted in the sensor sleeve. This ensures safe and stable positioning of the probe and ensures constant contact pressure. A V-groove in the sleeve of the probe facilitates reliable readings on small cylindrical parts. The hemispherical tip of the probe is made of hard and durable material. Hold the probe by the spring mounted sleeve when applying pressure on the measured object.

Description

Meter Description

1. LCD display
2. Power button
3. Sensing Probe
4. Navigation buttons

Note: Battery compartment on rear of meter

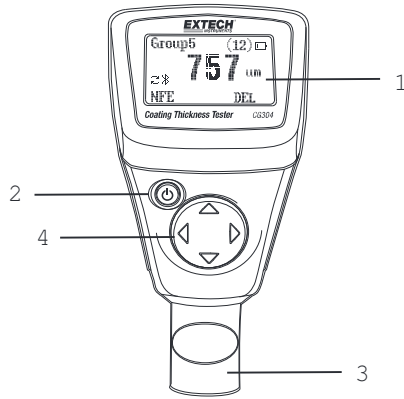

Display Description

1. Data record memory group number
2. Record Number in current memory group
3. Bluetooth icon
4. Automatic (Auto) metal detect mode
5. Battery status icon
6. Measurement units: μm = Micrometers;
mils = millimeters * 2.54/100
7. Metal type (FE=ferrous, NFE=non-ferrous)
8. Measurement reading
9. DEL (Delete): Press the RIGHT arrow button to delete the displayed reading

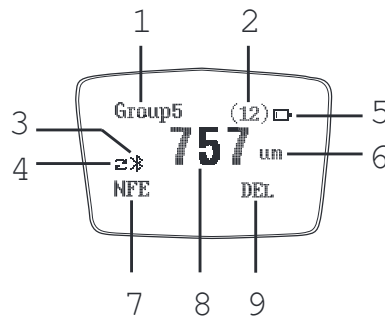

Operation

Meter Power

Install two 'AAA' 1.5 V batteries into the rear battery compartment. Press the power button  to switch the meter ON. The display will switch ON. If the display does not switch ON, install or replace the batteries. When powering up, please keep the meter at least 10cm (4") from metal objects. Replace the batteries when the battery status icon appears low, the meter will give inaccurate readings if the battery voltage falls very low.

Measurements

Before each measurement session please perform a Zero Calibration as described later in this User Guide. Practice with the film and zero (round) reference metal substrates to learn how the meter operates before moving to a professional application. The heavier metal substrate is the ferrous (magnetic) zero substrate and the lighter metal substrate is the non-ferrous (non-magnetic) zero substrate. The meter automatically senses ferrous and non-ferrous substrates.

1. Place a reference film (250µm, for example) on the round, ferrous substrate.
2. Power the meter by pressing the power button if necessary.
3. Place the spring-loaded meter sensor against the reference film.
4. The meter will emit an audible tone indicating that the measurement has been taken.
5. The LCD will show the reading (250µm) at the center of the display area.

6. A typical display will also show the following:

- Group(x): Upper left; Reading Memory Group number (0~50). Use the up/down arrow buttons to scroll groups
- (x): Upper right; Number of readings (0~50) stored in current group
- Battery status icon at upper right
- DEL: Press the RIGHT arrow button to delete the displayed reading
- Fe or NFE: Ferrous or Non Ferrous substrate on the lower left of the LCD
- Bluetooth icon: When Bluetooth operation is active
- Automatic Metal detect mode (dual arrows)

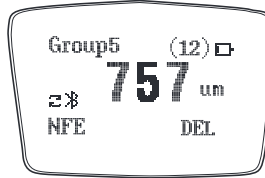

Experiment with the remaining reference films and the substrates before using the meter professionally.

Automatic Power OFF

In order to conserve battery life, the meter will automatically turn off after approximately 3 minutes. To defeat this feature use the programming menu detailed in the next section (menu parameter AUTO POWER OFF under SET).

Programming Menu

The meter can be configured and calibrated through simple button presses in the programming menu.

- Press the LEFT button to access the menu; refer to the menu ‘tree’ below.
- Use the UP/DOWN buttons to scroll the menu
- Use the LEFT button to select the highlighted mode
- Use the RIGHT button to back out of a mode
- Other button presses are mode specific, follow on-screen prompts explained below.

In the table below the factory default settings are in bold with an asterisk. Each parameter is explained in detail in the subsequent sections.

Top level	Sub level 1	Sub level 2	Description
WORKING MODE	Group 1...50		Shows Memory Groups and the number of readings in each group
MEASURE MODE	NFE, FE, Auto*		Non-Ferrous, Ferrous, or Auto (Automatic) Metal selection
SET	Unit settings	µm*	Micrometers
		Mil	Mils = mm * 2.54 / 100
	Backlight	Increase/decrease backlight using a up/down arrows	
	Auto Power OFF	Enable*	Allows Auto Power OFF
		Disable	Defeats Auto Power OFF feature
	Bluetooth	Enable	Bluetooth communication enabled
		Disable*	Bluetooth communication disabled
	Contrast	Increase/decrease contrast using up/down arrows	
Info	Shows firmware version number and meter Serial Number		
MEASURE VIEW	View or delete stored data in all groups or selected groups		
CALIBRATION	CAL Zero of FE	Perform Fe Zero Calibration (refer to Calibration section)	
	CAL Zero of NFE	Perform nFe Zero Calibration (refer to Calibration section)	
	Delete Zero	Delete Fe Zero Calibration data	
	Delete Zero	Delete nFe Zero Calibration data	

NOTE: Disable the Auto Power OFF feature before lengthy programming to avoid inconvenient automatic power down while programming.

WORKING MODE MENU

1. Press the LEFT button to access the menu.
2. Scroll to WORKING MODE (if necessary) using up/down buttons.
3. Press the LEFT button (SELECT) to open WORKING MODE.
4. Use the UP and DOWN buttons to scroll through the groups and to see the number of saved readings in each group.
5. Press the LEFT button (SELECT) to return to the main menu or press the RIGHT button (BACK) twice to return to the normal operating mode.

MEASURE MODE MENU

1. Press the LEFT button to access the programming menu
2. Use the UP/DOWN buttons to scroll to the Measure Mode
3. Press the LEFT button (SELECT) to select the Measure Mode
4. Use the UP/DOWN buttons to scroll to Auto, FE, or NFE. Press the LEFT button (SELECT) to make a selection.
In the AUTO mode, the meter automatically recognizes the metal that is being measured.
In the Ferrous (FE) Mode the Magnetic induction measurement mode is used.
In the Non-Ferrous (NFE) Mode the eddy current measurement mode is used.
5. Press the RIGHT button (BACK) to return to the normal operating mode.

SET MENU

1. Press the LEFT arrow to enter the menu.
2. Use the UP/DOWN arrows to scroll to SET.
3. Press the LEFT button (SELECT) to open the SET menu.

a. Units of measure selections

From the SET menu, scroll to the UNITS selection if necessary. Press the LEFT button (SELECT) to open UNITS. Select μm or mil using the arrow buttons (μm = micrometers; mils = $\text{mm} \times 2.54/100$). Press the LEFT button (SELECT) button to confirm and to return to the SET menu (otherwise press the right button [BACK] to abort the edit and return to the SET menu).

b. Backlight

From the SET menu, scroll to the BACKLIGHT selection. Press the LEFT button (SELECT) to open BACKLIGHT. Use the UP and DOWN arrows to adjust the brightness of the backlight. Press the RIGHT button (Back) to confirm and return to the SET menu.

c. Auto Power OFF

From the SET menu, scroll to the Auto Power OFF selection. Press the LEFT button (SELECT) to open Auto Power OFF. Select ENABLE or DISABLE using the arrow buttons. When enabled, the meter automatically switches OFF after 3 minutes of inactivity. When disabled, the meter will only switch OFF with a power button press or when the battery power is weak. Press the LEFT button (SELECT) button to confirm and to return to the SET menu (otherwise press the right button [BACK] to abort the edit and return to the SET menu).

d. Bluetooth

From the SET menu, scroll to the BLUETOOTH selection. Press the LEFT button (SELECT) to open BLUETOOTH. Select DISABLE or ENABLE using the arrow buttons. If Disable is selected the Bluetooth will be switched OFF. When Bluetooth is enabled, data will be automatically sent to PC, phone, or other Bluetooth receiving device.

When the first connection is being made the device may prompt for a PIN number. In this case enter code 0000.

Note: Turn on Bluetooth only when necessary as the battery will drain more quickly with Bluetooth powered ON.

Press the LEFT button (SELECT) button to confirm and to return to the SET menu (otherwise press the right button [BACK] to abort the edit and return to the SET menu).

e. Contrast

From the SET menu, scroll to the CONTRAST selection. Press the LEFT button (SELECT) to open CONTRAST. Use the UP and DOWN arrow buttons to adjust the contrast. Press OK to return to the main menu or select BACK to return to the SET menu.

f. Info

From the SET menu, scroll to the INFO selection. Press the LEFT button (SELECT) to open INFO. View the firmware version and serial number of the meter.

Use the RIGHT button (BACK) to move back through the menu items all the way to the normal measurement mode if desired.

MEASURE VIEW MENU

The Measure View menu allows for scrolling through the readings in all of the groups. Readings can be viewed or deleted in this mode.

1. Press the LEFT button to access the main menu.
2. Use the DOWN ARROW button to scroll down to MEASURE VIEW.
3. Press LEFT (SELECT) to open the MEASURE VIEW parameter.
4. Use the UP/DOWN ARROW buttons to scroll through the groups of stored readings.
5. When a group is highlighted that contains stored readings, use the LEFT arrow button to open the readings list. Now use the UP/DOWN arrows to view the readings. Press the LEFT button (Delete Group) to delete all readings in this Group or press the RIGHT button (BACK) to return to the main Group list.
6. Highlight 'Delete All' and press the LEFT button (SELECT) to delete all of the readings in all groups. Otherwise press the RIGHT button (BACK) to return to the previous menu.

CALIBRATION MENU

The Calibration menu allows the user to perform a ferrous (Zero F) or non-ferrous (Zero N) ZERO Calibration. The Calibration menu also allows the user to delete ZERO calibration data for both ferrous (Zero F) and non-ferrous (Zero N) modes.

1. Press the LEFT button to access the main menu.
2. Use the DOWN button to scroll to CALIBRATION.
3. Press LEFT (SELECT) to open the CALIBRATION parameter.
4. To perform a ZERO Calibration, refer to Zero Calibration in the next section.
5. To delete ZERO Calibration data, scroll to **DEL Zero of FE** or **DEL Zero of NFE** and then press the LEFT button (SELECT). This executes the Zero delete function and returns the meter to the SET menu.
6. Press the RIGHT button (BACK) to return to the normal operating mode.
7. Note that the user can access the ZERO Calibration modes from the normal measurement mode by pressing and holding the DOWN arrow button (for Ferrous) or the UP arrow button (for Non-Ferrous).

ZERO Calibration

Calibration Introduction

The meter is factory calibrated before shipment to the customer; however the customer should perform a Zero Calibration before any critical measurements are taken.

Preparing for ZERO Calibration

1. Clean the probe tip (grease, oil, metal scrap, and the slightest impurity will affect measurement and will distort readings).
2. Switch the meter ON at a 10 cm (4") minimum distance from any metal.
3. Ready the supplied metal substrate.
4. The meter is now ready for calibration.

Zero Calibration

The user can access the ZERO Calibration utility from the normal measurement mode or from the Programming Menu.

ZERO Calibration from the normal measurement mode

1. Press and hold the UP arrow button to access the NFE (non-ferrous) Zero Calibration screen
2. Press and hold the DOWN arrow button to access the FE (ferrous) Calibration screen.
3. At the desired calibration screen press the sensor against the FE or NFE zero reference substrate.
4. Press the LEFT button (OK) to accept the calibration value or press the RIGHT button (CANCEL) to abort the calibration.

ZERO Calibration screens from the Programming Mode

1. From the normal measurement mode, press the LEFT button to access the menu.
2. Use the DOWN button to scroll to the CALIBRATION mode.
3. Press LEFT (SELECT) to open the CALIBRATION parameter.
4. Scroll to 'CAL ZERO OF FE' or 'CAL ZERO OF NFE'
5. Press the LEFT button (SELECT) and 'CAL FE' or 'CAL NFE' should be displayed on the LCD's lower right.
6. Press the sensor against the FE or NFE zero reference substrate.
7. Press the LEFT button (OK) to accept the calibration value or press the RIGHT button (CANCEL) to abort the calibration.
8. Note that the user can delete ZERO Calibration data by selecting 'Del ZERO of FE' or 'Del ZERO of NFE' from the CALIBRATION mode in the Programming menu.

Record Readings in Memory Groups

The CG304 offers 50 memory storage groups, Group '0' through '50'.

Group '0' does not allow data to be stored; it is simply a group that can be selected if readings are to be taken without being stored.

Use the UP/DOWN arrow keys to scroll to a particular group. When a reading is taken it is automatically stored in the selected group (except if Group '0' is selected). Each Group can store up to 50 readings (for a total of 2500 for the 50 groups).

To delete all groups, or an individual group, use the MEASURE VIEW mode as explained in the programming menu section of this User Guide.

In GROUP mode, if the storage capacity is exceeded. The meter's display will show 'Data Full'.

Bluetooth®

This meter has the capability to connect to and communicate with a PC via Bluetooth. To transfer data, enter the SET Menu and switch on Bluetooth as explained below and the Programming Menu section earlier in this guide. Measurement data will be sent automatically by way of the Bluetooth utility.

Select ENABLE or DISABLE under Bluetooth in the SET Menu using the arrow buttons. If disable is selected the Bluetooth will be completely disabled. When Bluetooth is enabled data will be automatically sent to PC, phone, or other Bluetooth receiving device.

When the first connection is made the device may prompt for a PIN number. In this case enter code 0000.

Note: Use Bluetooth only when necessary as the battery will drain more quickly with Bluetooth powered ON.

Check the software download page of the website www.extech.com for the latest version of the PC software and its operating system compatibility.

FCC COMPLIANCE

This device complies with part 15 of the FCC Rules. Operation is subject to the following two conditions:

1. This device may not cause harmful interference.
2. This device must accept any interference received, including interference that may cause undesired operation.

This equipment has been tested and found to comply with the limits for a Class B digital device, pursuant to part 15 of the FCC Rules. These limits are designed to provide reasonable protection against harmful interference in a residential installation.

This equipment generates, uses, and can radiate radio frequency energy harmful interference to radio communications. However, there is no guarantee that interference will not occur in a particular installation. If this equipment does cause harmful interference to radio or television reception, which can be determined by turning the equipment off and on, the user is encouraged to try to correct the interference by one or more of the following measures:

- Reorient or relocate the receiving antenna.
- Increase the separation between the equipment and receiver.
- Connect the equipment into an outlet on a circuit different from that to which the receiver is connected.
- Consult the dealer or an experienced radio/TV technician for help.



CAUTION: FCC Radiation Exposure Statement

1. This transmitter must not be co-located or operating in conjunction with any other antenna or transmitter.
2. This equipment complies with FCC RF radiation exposure limits set forth for an uncontrolled environment.
3. To maintain compliance with FCC RF exposure compliance requirements avoid direct contact to the transmitting antenna during transmission.



WARNING: Changes or modifications not expressly approved by the party responsible for compliance could void the user's authority to operate the equipment.

INDUSTRY CANADA (IC) COMPLIANCE

This device complies with Industry Canada license-exempt RSS standard(s). Operation is subject to the following two conditions: (1) this device may not cause interference, and (2) this device must accept any interference, including interference that may cause undesired operation of the device.



CAUTION: IC Radiation Exposure Statement

1. This transmitter must not be co-located or operating in conjunction with any other antenna or transmitter.
2. This equipment complies with RSS 102 RF radiation exposure limits set forth for an uncontrolled environment.
3. To maintain compliance with RSS 102 RF exposure compliance requirements avoid direct contact to the transmitting antenna during transmission.

Error Messages

The following error messages will appear on the meter's LCD if a problem arises.

Err1	Eddy current probe error
Err2	Magnetic induction probe error
Err3	Eddy current and Magnetic induction errors
Err4, 5, 6	Unused error displays
Err7	Thickness error

Please contact Extech Instruments if a problem exists.

Maintenance

Cleaning and Storage

Periodically wipe the meter housing with a damp cloth and mild detergent; do not use abrasives or solvents. If the meter is not to be used for 60 days or more, remove the batteries and store them separately.

Battery Replacement/Installation instructions

1. Open the latched rear battery door
2. Replace/install the two 1.5V 'AAA' batteries observing proper polarity
3. Secure the battery compartment



Never dispose of used batteries or rechargeable batteries in household waste. As consumers, users are legally required to take used batteries to appropriate collection sites, the retail store where the batteries were purchased, or wherever batteries are sold.

Disposal: Do not dispose of this instrument in household waste. The user is obligated to take end-of-life devices to a designated collection point for the disposal of electrical and electronic equipment.

Specifications

	Ferrous	Non-Ferrous
Measurement principle	Magnetic induction	Eddy current principle
Measuring range	0~2000µm 0~78.7mils	0~2000µm 0~78.7mils
Accuracy ¹ (% of reading)	0~1000µm: ±(2% + 2µm) 1000µm ~2000µm: (±3.5%) 0~39.3mils: ±(2% + 0.08mils) 39.3mils ~78.7mils: (±3.5%)	0~1000µm: ±(2% + 2µm) 1000µm ~2000µm: (±3.5%) 0~39.3mils: ±(2% + 0.08mils) 39.3mils ~78.7mils: (±3.5%)
Resolution	0~100µm: (0.1µm) 100µm ~1000µm: (1µm) 1000µm ~2000µm: (0.01µm) 0~10mils: (0.01mils) 10mils~78.7mils: (0.1mils)	0~100µm: (0.1µm) 100µm ~1000µm: (1µm) 1000µm ~1000µm: (0.01µm) 0~10mils: (0.01mils) 10mils~78.7mils: (0.1mils)
Min. curvature radius	59.06mils (1.5mm)	118.1mils (3mm)
Diameter of Min. area	275.6mils (7mm)	196.9mils (5mm)
Basic critical thickness	19.69mils (0.5mm)	11.81mils (0.3mm)
Industrial standards	Conforms to GB/T 4956-1985, GB/T 4957-1985, JB/T 8393-1996, JJG 889-95, and JJG 818-93	
Operating Temperature	0°C~40°C (32°F~104°F)	
Operating Relative Humidity (R.H.)	20%~90% Relative Humidity	
Power	2 x AAA batteries with Auto Power OFF after 3 minutes	
Dimensions	120 x 62 x 32 mm (4.7 x 2.4 x 1.25")	
Weight	175g (6.17 oz.)	
¹ Accuracy note: Accuracy statement applies to use on a flat surface, with a zero calibration performed and with the meter stabilized at ambient temperature. The accuracy of the reference films or any reference standards should be added to measurement results.		

Copyright © 2015 FLIR Systems, Inc.

All rights reserved including the right of reproduction in whole or in part in any form
www.extech.com